

# Evaluating Battery Run-down Performance Using the Agilent 66319D or 66321D and the 14565B Device Characterization Software

Application Note 1427

The Agilent 66319D and 66321D mobile communications DC sources are specialized products ideally suited for directly powering and measuring current drain on many mobile wireless devices. Together with the 14565B device characterization software, they provide an easy way of performing long-term battery current drain measurement and analysis.

There are also times when it is advantageous to use a battery instead of the DC source to power the mobile device. This application note describes a detailed procedure on how this solution can also be used to easily and accurately evaluate performance of the mobile device while being directly powered by its battery. This greatly simplifies a task that is normally time consuming and cumbersome when using traditional approaches.

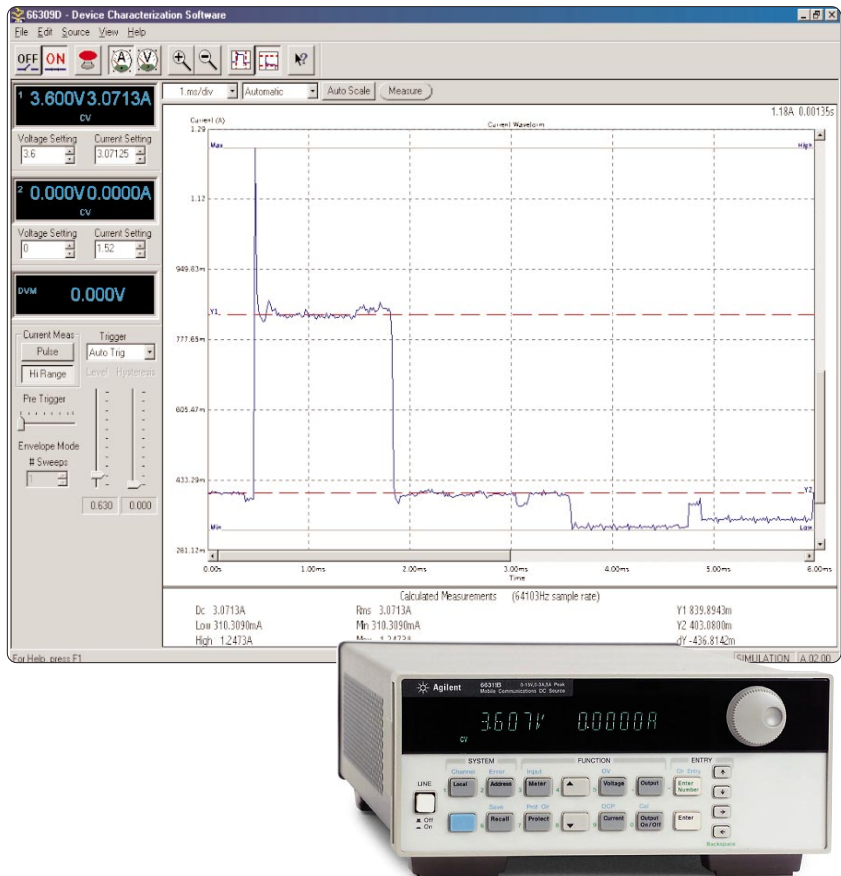

## Advantages of Measuring Battery Run-down Performance

The overall process of evaluating and optimizing battery operating time dictates running several tests and measurements on the battery and the mobile wireless device, both independently and together as a system. Evaluating the battery and mobile device together has some specific advantages. It enables the test engineer to:

- Validate the actual operating time to compare against expected value.
- Verify battery capacity and performance in its end application to correlate against the battery manufacturer's standard specifications.
- Evaluate peak and average current and power consumption of the device when powered by its battery to compare against expected values and aid in optimizing device performance.

The last two items require an accurate, long-term, “non-intrusive” current measurement that does not influence the result.

### Some challenges of traditional approaches

Traditional approaches using shunts to measure battery-drain pose a challenge of meeting the accuracy required for the wide dynamic range of current, without influencing the result. This is because the resultant voltage drop on the shunt can become a problem when powering a device from a low voltage battery. In contrast, the 66319D or 66321D when configured as described in this application note, act as a zero ohm shunt thus not contributing to any voltage drop that may affect results.

Battery run-down tests can easily run for hours to days in length. Additional challenges with traditional approaches include the logging and storage

of the massive quantity of data generated, and the subsequent post-test analysis and display of results. This typically requires considerable software development time and effort. The 14565B device characterization software dispenses with any programming. It is a ready-to-use platform providing long-term measurement acquisition and includes post-test result visualization and analysis tools.

### Recommended set-up when using the Agilent 66319D or 66321D

Figure 1 depicts the recommended set-up for using the Agilent 66319D or 66321D for measuring the battery run-down performance. A number of key considerations described here in detail, will assure optimum results when using this configuration.

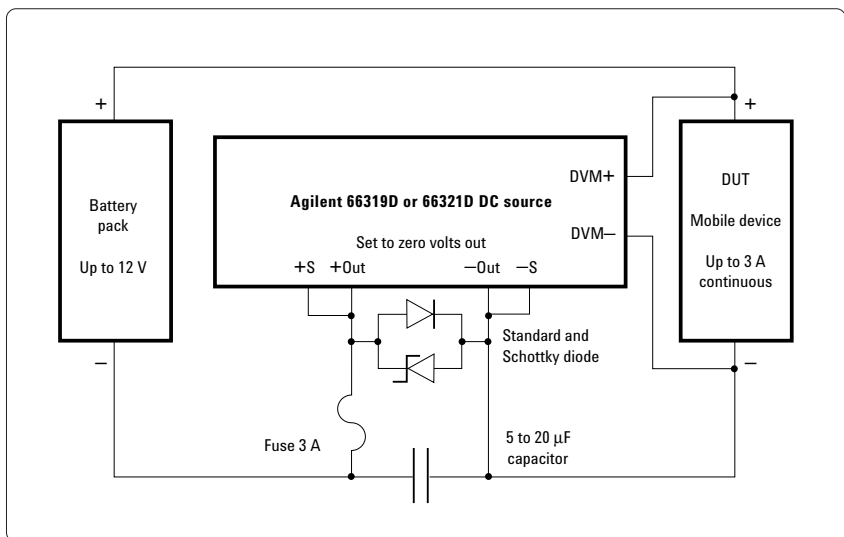

Figure 1. Recommended test set-up

### Measuring battery current using the zero-ohm shunt capability

When the 66319D or 66321D DC source is connected in series with the battery and mobile wireless device, and its output programmed to zero volts and enabled, it behaves as a zero ohm shunt with precision current read back. Unlike most power supplies, these DC sources are designed to source and sink current and maintain excellent regulation down to zero volts out. Note that the DC source plus (+) output is connected to the minus (-) terminal of the battery pack and the DC source minus (-) output is connected to the minus (-) terminal of the mobile wireless device. This orientation allows the battery drain current to be measured as a positive value by the DC source.

### Measuring battery voltage using the separate DVM input

The DVM option on the DC source is required in order to additionally measure the battery run-down voltage. The DVM option is denoted by a D suffix on the model number. Connecting the DVM input with a second set of leads across the device, as depicted in **Figure 1**,

makes the voltage measurement. Note that the DC source output is connected in the low side of the circuit. This assures the DVM is operating well within its acceptable common mode voltage range with respect to the DC source's minus (-) output.

*Note:* If battery voltage measurement is not needed, the 66319B or 66321B model, without the separate DVM input will suffice for measuring just the current drain.

### Protecting against battery pack over-currents

Care must be taken when using batteries, as many types are capable of supplying extremely high currents if misapplied or shorted. What has been referred to so far as a battery is the battery pack, not just the battery cells. There are some important considerations for using the battery pack as opposed to using the battery cells directly:

- The battery pack typically incorporates an overload circuit to protect itself and the user in the case of a short or misapplication. Under no circumstances should battery cells be used without any overload protection.
- Additional devices exist within the battery pack in series with the battery cells that contribute to the overall output resistance. Because of this more accurate battery run-down test results are obtained by using the complete battery pack.

- Complete battery packs are more readily recharged as they typically incorporate charging support circuitry. Using the OEM battery charger may be necessary to assure that truly accurate results are obtained. The particular charge method employed by the charger determines the final charge level of the battery pack. Because of this, the battery charger may also be a key part to be validated together with the battery pack and mobile wireless device.
- Under no circumstances should the battery pack or battery cells be charged with anything other than an approved battery charger.

An external protection network consisting of two diodes and a fuse, as shown in **Figure 1**, is required. This protects the mobile wireless device and DC source against battery pack over-currents in the event of a misapplication, short, or fault. The protection network components match the 3-ampere continuous output rating of the DC source. Under normal operation the diodes are both off because the power supply regulates its output at zero volts and conducts all of the battery-drain current. Continuous currents in excess of three amperes will drive the power supply out of voltage regulation. Excess current then conducts through the appropriate diode until the fuse opens.

### Minimizing transient voltage drop

Minimizing the transient voltage drop across the DC source output is desirable as this voltage drop momentarily reduces the full battery voltage powering the mobile device during its loading transients. It is important to use local voltage sensing at the output of the DC source for this set-up. This is accomplished by connecting plus (+) sense to the plus (+) output and minus (-) sense to the minus (-) output, as shown in **Figure 1**.

Adding an external 5 to 20  $\mu\text{F}$  film or low ESR ceramic capacitor across the protection network and setting the power supply to its “Hlocal” compensation mode minimizes the transient voltage drop across the DC source output, when set up for the local voltage sense operation as used in this application.

A practical example of the external protection and compensation network is pictured in **Figure 2**. The suggested parts are listed in **Table 1**.

### Minimizing and compensating for wiring resistance

Just as with the transient voltage drop, it is also necessary to minimize the DC voltage drop due to the wiring and fuse resistance. In this example total wiring resistance, including the protection network assembly, was around 12 milliohms. This was accomplished by



**Figure 2.** Example of an external protection network and DVM leads

**Table 1** List of suggested parts for an external protection network

| Component        | Ratings                | Manufacturer | Manufacturer part number | Agilent part number |
|------------------|------------------------|--------------|--------------------------|---------------------|
| Silicon diode    | 3 A                    | Motorola     | 1N5406                   | 1901-0759           |
| Schottky diode   | 3 A                    | Motorola     | 1N5822                   | 1901-0992           |
| Fuse             | 3.15 A                 | Schurter     | FSF 034.1521             | 2110-0655           |
| Capacitor        | 6.8 $\mu\text{F}$ film | Wima         | MKS4 6.8 $\mu\text{F}$   | 0160-7562           |
| Output connector | 5 pin                  | —            | —                        | 0360-2604           |
| Sense jumper     | 2 pin                  | —            | —                        | 8120-8821           |
| DVM connector    | 3 pin                  | —            | —                        | 1252-8670           |

## Measuring Battery Run-down Performance with the 14565B Software

keeping the wiring reasonably short and heavy. The fuse used for this example was selected for its low resistance of about 20 milliohms. Keeping connections tight minimizes the contact resistance contribution.

Because remote sensing is not suited for this set-up, it cannot be used to offset wiring resistance. Note, however, that these DC sources incorporate a unique negative output resistance capability. The voltage at the mobile device will match the battery voltage when the negative resistance setting matches the wiring resistance. Negative resistance can be easily set to compensate for up to 40 milliohms of wiring resistance to assure that the full battery voltage powers the mobile wireless device during testing.

The 14565B device characterization software can measure battery current drain from seconds– to weeks in duration. The data log mode of operation is particularly useful for visualizing, quantifying, and analyzing battery run-down test results.

An example of a battery run-down test using the 14565B data log mode is illustrated in **Figure 3**. The upper plot is the battery run-down voltage. The lower three plots are the peak, average, and minimum values of battery-drain current. In addition to graphing, numerical test results are tabulated and displayed in the lower window. Just as with the hardware, there are some key considerations for setting up the software when running the data log mode.

### Setting the current measurement integration period

This is the time period for each point saved in the data log, summarizing the data, which is sampled at a 64 kHz rate during that period. The integration period can be set from 31.2 microseconds to 1 second. Shorter integration periods increase the data rate, which can exceed the system's continuous transfer data rate limit. This will cause the test to terminate early. Thus, it is important to select a long enough integration period to allow for continuous acquisition. It is also desirable to set the integration period long enough to provide an appropriate amount of signal integration, i.e. several periods of the signal of interest is accumulated. As one example, the peak tracking will jump between the average

**Figure 3.** 14565B Data log mode displaying a battery run-down test

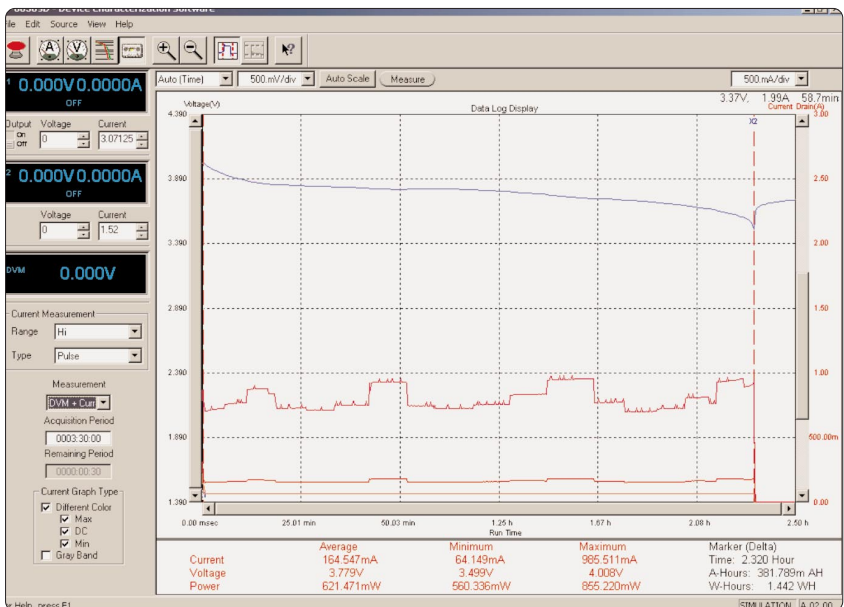

## Built-in Post-Test Results Analysis

and peak values with a short integration period but will become a continuous envelope with a suitably long integration period.

### Selecting the parameters to be measured

The data log can be set to measure “current”, “current and output voltage”, or “current and DVM”. If it is important to measure battery current only then the preferable choice is to select “current” as this will provide continuous high-speed current sampling. If it is important to measure both battery current and voltage then “current and DVM” setting is selected. With this setting the measurement system switches over to sample the DVM voltage around once every ten seconds to capture the battery run-down voltage profile. This produces a small discontinuity in the current waveforms, which are interpolated by the software.

### Setting the time duration of the test

The test time is set in minutes, hours, and days. It should be set to run in excess of the expected actual battery run-down duration to ensure that the entire event is captured.

Many useful key results can be readily obtained from the data log display shown in **Figure 3**, as many functions are already built into the software to perform cumulative analysis on the data log.

### Setting markers to analyze the battery-run down period

The dip and recovery near the end of the data log for the battery voltage, coinciding with abrupt drop-off of drain current, is the low battery voltage shut down point of the mobile device. Turning on the vertical measurement markers and placing them at the start and shut down points sets up the software to base all numerical calculations over just the run-down period, instead of the entire display.

### Obtaining battery-operating time, ampere-hour and watt-hour results

A fourth column of numerical values appears in the calculated measurements window when the vertical markers are turned on. As shown, battery-operating time is validated for the mobile wireless device in conjunction with its battery. Cumulative ampere-hours and watt-hours of consumption are also calculated and are useful for validating and correlating against specified battery capacity and expected mobile device consumption.

### Identifying and analyzing anomalous behaviors affecting operating-time

The first three columns of numerical values, recalculated to the vertical marker positions, along with the data log plots, are useful for diagnostics and analysis when correlating actual results against expectations and when optimizing battery-operating time.

The high-speed sampling and peak current tracking identifies unusually high peak current anomalies. High peak current anomalies induce premature low battery voltage shutdown and lead to unexpectedly short battery-operating time.

The software creates a detailed data log file can be later recalled, expanded, and reviewed to diagnose the mobile wireless device operation. Particular activities can be identified along with their frequency of occurrence, and their peak and average consumption assessed, to identify causes of differences between actual and expected operating time and consumption.

The average voltage and discharge plot can be correlated against the battery midpoint voltage and published discharge curves. This is another factor affecting operating-time and obtained capacity.

## Summary

Conducting testing on a mobile wireless device in combination with its battery has some specific advantages when validating and optimizing battery operating life. Testing battery run-down performance enables the test engineer to:

- Validate the actual operating time to compare against expectations.
- Verify battery capacity and performance in its end application to correlate against the manufacturer's standard specifications.
- Evaluate peak and average currents and power consumption of the device when powered by its battery, to compare against expected values and aid in optimizing performance of the mobile device.

The Agilent 66319D and 66321D mobile communications DC sources are specialized products ideally suited for directly powering and measuring current drain

on many wireless mobile devices. Adding the 14565B device characterization software provides a way of performing long-term battery current drain measurement and analysis. It is an easy to use solution supporting long-term measurement acquisition and includes post-test results visualization and analysis tools. By following the steps detailed in this product note, this solution can now also be used to easily and accurately evaluate battery run-down performance.



### Agilent Email Updates

#### [www.agilent.com/find/emailupdates](http://www.agilent.com/find/emailupdates)

Get the latest information on the products and applications you select.



### Agilent Direct

#### [www.agilent.com/find/quick](http://www.agilent.com/find/quick)

Quickly choose and use your test equipment solutions with confidence.



#### [www.agilent.com/find/open](http://www.agilent.com/find/open)

Agilent Open simplifies the process of connecting and programming test systems to help engineers design, validate and manufacture electronic products. Agilent offers open connectivity for a broad range of system-ready instruments, open industry software, PC-standard I/O and global support, which are combined to more easily integrate test system development.



is the U.S. registered trademark of the LXI Consortium.

## Remove all doubt

Our repair and calibration services will get your equipment back to you, performing like new, when promised. You will get full value out of your Agilent equipment throughout its lifetime. Your equipment will be serviced by Agilent-trained technicians using the latest factory calibration procedures, automated repair diagnostics and genuine parts. You will always have the utmost confidence in your measurements.

Agilent offers a wide range of additional expert test and measurement services for your equipment, including initial start-up assistance onsite education and training, as well as design, system integration, and project management.

For more information on repair and calibration services, go to

[www.agilent.com/find/removealldoubt](http://www.agilent.com/find/removealldoubt)

## www.agilent.com

For more information on Agilent Technologies' products, applications or services, please contact your local Agilent office. The complete list is available at:

[www.agilent.com/find/contactus](http://www.agilent.com/find/contactus)

### Phone or Fax

#### United States:

(tel) 800 829 4444  
(fax) 800 829 4433

#### Canada:

(tel) 877 894 4414  
(fax) 800 746 4866

#### China:

(tel) 800 810 0189  
(fax) 800 820 2816

#### Europe:

(tel) 31 20 547 2111

#### Japan:

(tel) (81) 426 56 7832  
(fax) (81) 426 56 7840

#### Korea:

(tel) (080) 769 0800  
(fax) (080) 769 0900

#### Latin America:

(tel) (305) 269 7500

#### Taiwan:

(tel) 0800 047 866  
(fax) 0800 286 331

#### Other Asia Pacific Countries:

(tel) (65) 6375 8100  
(fax) (65) 6755 0042  
Email: [tm\\_ap@agilent.com](mailto:tm_ap@agilent.com)

Revised: 09/14/06

Product specifications and descriptions in this document subject to change without notice.

Bluetooth is a trademark owned by Bluetooth SIG, Inc., U.S.A. and licensed to Agilent Technologies, Inc.

© Agilent Technologies, Inc. 2007  
Printed in USA, January 31, 2007  
5988-8157EN



Agilent Technologies